



SUSPA GmbH

Assembly Instructions

English

Table Frame Type FixFrame



The assembly instructions must be read carefully prior to initial commissioning!

Follow the safety instructions!

This table frame is intended to be incorporated into machinery, partly completed machinery/equipment or to be joined with another framework so as to form a complete machine as specified under the Machinery Directive. The machine should be put into operation only after a conformity evaluation procedure in accordance with the Machinery Directive has been carried out for the complete machine.

No revision service applies to this documentation. The updated assembly instructions are available at

<http://www.suspa.com/de/service/downloads/>

These assembly instructions are part of the technical documentation.

These assembly instructions are addressed to the person in charge who must pass it on to the personnel responsible for connection, use, and maintenance of the machine. He must ensure that the information contained in these assembly instructions and in the accompanying documents has been read and understood.

These assembly instructions must be kept at a commonly known and easily accessible location and they must be consulted even if the slightest doubt arises.

The manufacturer is not liable for injuries to people or animals, and damage to objects or to the machine itself arising from the improper/unauthorized use or by ignoring the safety criteria contained in these assembly instructions or by modification of the machine or use of unsuitable spare parts.

The copyright for these assembly instructions is solely held by



SUSPA GmbH
Mühlweg 33
90518 Altdorf
GERMANY

or its legal successor.

The contents of the user information is the intellectual property of SUSPA GmbH.

SUSPA GmbH expressly reserves the ownership of and copyright to the data contained in the user information.

Reproduction and duplication, even in excerpts, are permitted only upon the written consent of SUSPA GmbH.

Status: August 2019

1	Information concerning this document.....	5
1.1	Structure of the warnings.....	5
1.2	Signal words and signal colors.....	5
1.3	Symbols.....	6
1.3.1	Warning Notice	6
2	Identification and Notes.....	7
2.1	Designation.....	7
2.2	Manufacturer.....	7
2.3	Intended use.....	7
2.4	Reasonably foreseeable misuse	8
2.5	General Instructions	9
2.5.1	Warranty and liability.....	9
2.5.2	Objective of the assembly instructions.....	9
2.5.3	Target group of the assembly instructions.....	10
3	Safety Instructions	11
3.1	Obligations.....	11
3.1.1	Responsibilities of the operating company.....	12
3.2	Additional Instructions	12
4	Design and function.....	13
4.1	Technical specifications.....	13
4.2	Design and function of the table frame	14
4.2.1	Packaging units and weights	16
5	Installation	17
5.1	Unpacking	17
5.1.1	Disposal of transport and warehouse packaging.....	17
5.1.2	Checklist of all components included in the delivery	17
5.2	Operating conditions.....	18
5.3	Installation of components	19
5.3.1	General installation.....	19
5.3.2	Installation of the table base frame	20
5.3.2.1	Alignment of the lifting columns.....	21
5.3.2.2	Positioning the cross beams	22
5.3.2.3	Positioning the fixing plate.....	23
5.3.2.4	Screwing on the frame components.....	24
5.3.2.5	Screw connection of the table base frame to the tabletop.....	25
5.3.2.6	Installation of the foot base and adjustable glides.....	26
5.3.2.7	Installation of the electrical controller (exemplary).....	28
5.3.2.8	Installation of the manual switch (exemplary).....	29

5.3.2.9	Connections and electrical lines (exemplary)	30
5.3.2.10	Laying of electric wires and cables (exemplary).....	31
5.4	Space requirements	31
5.5	Setting up and aligning the table.....	32
6	Service and maintenance	33
6.1	General	33
6.2	Maintenance instructions	33
6.2.1	Cleaning	33
6.3	Maintenance	34
6.3.1	Overloading the table frame.....	34
6.3.2	Damages to electrical wires.....	34
7	Decommissioning	35
7.1	Component storage.....	35
7.2	Disposal of components.....	35
8	Appendix.....	36
8.1	Index of Tables.....	36
8.2	Index of Figures	37

1 Information concerning this document

1.1 Structure of the warnings

The combination of a signal word in conjunction with a pictogram classifies the respective warning. The symbol can vary depending on the type of danger.

⚠ THE WARNING IS GIVEN BELOW A SIGNAL WORD THAT INDICATES THE EXTENT OF THE EXISTING DANGER.

The first line after the signal word describes the type and source of the potential danger.

The following section describes the consequences if no measures are adopted to safeguard against the danger.

The last paragraph describes the measures to avoid the danger.

1.2 Signal words and signal colors

The following signal words are based on DIN EN 82079-1 and ANSI Z 535.4 and are used in this documentation. The safety colors have been taken from standard ISO 3864-1.



Signal word	Use	Explanation
 DANGER	Warning notice	Indicates a dangerous situation, which, if ignored, leads to death or severe injuries.
 WARNING	Warning notice	Indicates a dangerous situation, which, if ignored, may lead to injuries and damage to property
 CAUTION	Warning notice	Indicates a dangerous situation, which, if ignored, may lead to minor injuries and damage to property
IMPORTANT	Note	Refers to ways to facilitate and simplify operation and cross-references. It excludes the danger of damage to property and the risk of injuries.
SAFETY INSTRUCTION	Safety instruction	Draws attention to specific safety-relevant instructions or procedures.

Table 1 Signal words and signal colors

1.3 Symbols

Some of the following special safety symbols according to DIN EN ISO 7010: 2011 are used at the corresponding passages in the text of these assembly instructions and require special attention depending on the combination of signal word and symbol:

Symbol	Use	Explanation
	Note	Important information for understanding the device or for optimized operations.

Table 2 Symbols

1.3.1 Warning Notice



Symbol	Explanation	Symbol	Explanation
	General warning sign		Warning against hazardous electrical voltage
	Warning of hand injuries		

Table 3 Warning notice

2 Identification and Notes

2.1 Designation

FixFrame

Consisting of:

- Cross beam FixFrame
- Fixing plate
- Foot base-Q or Foot base-RE
- Fixframe installation kit

2.2 Manufacturer



SUSPA GmbH
 Mühlweg 33
 90518 Altdorf
 GERMANY

2.3 Intended use

The table frame serves as connecting element between a countertop and two lifting columns (ELS3) for seated or standing workstations in the office. Therefore, the foot base feet are attached to the lifting columns. These must then be attached to the upper frame sections. The preassembled table base frame is joined with the tabletop. The system is only designed for load that applies pressure.

IMPORTANT Prior to installation or commissioning, ensure that the appropriate table frame has been selected. Please note in this regard the technical specifications (see section 4.1 Technical specifications), in particular, the maximum load and adjustment range information.

Any other or advanced use of the table frame is deemed not to be in the manner intended and thus improper.

The table frame is intended to be incorporated into other machinery, other partly completed machinery/equipment or to be joined with another framework so as to form a complete machine as specified under the Machinery Directive. The machine should be put into operation only after a

conformity evaluation procedure in accordance with the Machinery Directive has been carried out for the complete machine.

SUSPA GmbH assumes no liability for damage resulting from such improper use.

Intended use also includes:

- following all instructions in the assembly instructions
- following all the safety instructions
- compliance with the maintenance intervals

2.4 Reasonably foreseeable misuse

Improper use that could result in risks posed to the user, third parties or to the table frame in all operating modes includes the following:

- using the table frame contrary to its intended use
- installation of the table frame on components that have not been approved by SUSPA GmbH for this system
- using components for the operation of the table frame, in this case the electrical controller, control elements and cables for the electrical connection of the components that have not been approved by SUSPA GmbH for this system
- improper installation, commissioning, operation and maintenance of the system
- operation of the table frame beyond the physical operating limits described in section "Operating conditions"
- any modifications to the table frame as well as any add-ons or conversions without prior consultation with the company, SUSPA GmbH
- operating the table frame contrary to the specifications provided in the operating instructions regarding safety instructions, installation, operation, and malfunctions
- operating the table frame with apparent malfunctions and/or defects



⚠ WARNING

Risk of sustaining injuries as a result of unauthorized modifications

Unauthorized modifications to the component as well as the use of spare parts from other manufacturers (not original spare parts) may pose risks.

Do not allow any unauthorized or other modifications to the component without prior approval of SUSPA GmbH.

IMPORTANT This equipment is not meant to be used by persons (including children) with limited physical, sensory and mental capabilities or lacking experience and/or knowledge, unless they are supervised by a person responsible for their safety or have received instructions from them about how the equipment has to be used. Children must be supervised in order to ensure that they do not play with the equipment.

2.5 General Instructions

2.5.1 Warranty and liability

The "General Terms and Conditions" of SUSPA GmbH always apply. They have been made available to the owner since the contract was signed at the latest.

Warranty claims and liability claims for personal injury and material damage are excluded if they are attributed to one or more of the following causes:

- Improper use of the component
- Improper installation, commissioning, operation and maintenance of the component
- Disregarding the information in the assembly instructions
- Unauthorized structural modifications to the table frame
- Inadequate implementation of the prescribed maintenance operations
- Disasters caused by external influence or force majeure
- Repairs that have not been carried out by the manufacturer's specialists

Read the assembly instructions carefully before commissioning and using the component. The assembly instructions should familiarize the user with the handling of the component and instruct the user in the details associated with function and maintenance. The assembly instructions must be made accessible to personnel at all times and must be kept available near the table frame. Read and observe the information on maintenance and operational safety in the assembly instructions. SUSPA GmbH would be pleased to answer any questions extending beyond the scope of these assembly instructions.

2.5.2 Objective of the assembly instructions

These assembly instructions serve as a support, and contain all necessary instructions that must be observed and complied with for general safety, transport, installation, operation, maintenance, storage and disposal.

These assembly instructions with all safety instructions as well as all additional documents of the assemblies provided by external suppliers must be:

- observed, read and understood by all persons working on the table frame; this applies, in particular, to the safety instructions
- easily accessible at all times to all persons
- consulted even in case of slightest doubt (safety)

Objectives:

- Prevent accidents
- Increase the service life and reliability of the component

IMPORTANT The right to technical modifications in the context of continuous product improvement is reserved at all times without prior notification!

2.5.3 Target group of the assembly instructions

At different life cycle phases of the table frame, personnel with varied competences may come into contact with the table frame.

Tasks	Specialized personnel	Company SUSPA GmbH	Private person
Shipping (Delivery)		X	
Transport (Dispatching)	X	X	X
Commissioning / installation	X	X	X
Operation	X	X	X
Troubleshooting	X	X	X
Repairs		X	
Decommissioning / Dismantling	X	X	X

Table 4 Target group

Specialized personnel

Persons who can evaluate the work assigned to them and recognize possible dangers on the basis of their specialized training, knowledge, experience and familiarity with the relevant standards.

External specialized personnel (SUSPA)

The external specialized personnel are specially trained for the manufacturer's products and is familiar with every life stages of the table frame. The external specialized personnel conduct the transport up to the transfer to the operator.

Private person

Persons who have no previous knowledge in the installation of mechanical and electrical components.

Outside the Federal Republic of Germany, the accident prevention regulations and safety provisions of the respective country apply.

3 Safety Instructions



WARNING

Risk of injury and material damage

There are risks posed by ignoring the assembly instructions and all safety instructions provided therein.

Read the assembly instructions carefully prior to first commissioning. Observe and adhere to the specified safety conditions. Observe and follow both the general safety instructions and also the special safety instructions provided in the other sections.

The components have been constructed using state-of-the-art technology and in line with established safety regulations. In order to prevent danger to life and limb of the user, third parties, or to the components, use the components only for intended purpose and in perfect operating condition in terms of safety.

The operator of the components or the persons assigned by the same are liable for property damage and personal injury resulting from non-compliance with the instructions provided in the assembly instructions.

3.1 Obligations



WARNING

Risk of injury by disregarding the safety symbols

A risk of sustaining injuries is posed associated with disregarding the warning notices provided in the area of the component and in the assembly instructions.

Heed all the warnings and safety notices in these assembly instructions.

The following circumstances could increase the hazard potential of the components:

- Hazard posed to persons through mechanical influences
- Malfunctions that may impair the safety during operation of the component

3.1.1 Responsibilities of the operating company

The table frame is intended to be incorporated into machinery, partly completed machinery/equipment or to be joined with another framework so as to form a complete machine as specified under the Machinery Directive. The machine should be put into operation only after a conformity evaluation procedure in accordance with the Machinery Directive has been carried out for the complete machine.

3.2 Additional Instructions

Basically, the provisions of the accident prevention regulations of the professional association also apply to all work on the table frame.

In addition, observe and follow

- Applicable and binding accident-prevention regulations
- Applicable and binding regulations at the place of use
- Recognized technical regulations for safe and professional working methods
- Existing environmental protection regulations
- Other applicable regulations

4 Design and function

4.1 Technical specifications

Technical specifications - Table frame					
Frame section dimensions (for the installation on tabletops)					
	Length				
Cross beam – pos. A :	1133 mm	1333 mm	1533 mm	1733 mm	1933 mm
Fixing plate – pos. B :	545 mm	545 mm	545 mm	545 mm	545 mm
	Length x width				
Suitable for tabletops:	1200 mm	1400 mm	1600 mm	1800 mm	2000 mm
	800 mm	800 mm	800 mm	800 mm	800 mm
Foot base Q dimensions (to be attached to ELS3 lifting column) – pos. C					
Length:	750 mm				
Width :	90 mm				
Height:	20 mm				
Hole pattern:	Round, section circle: 45 mm, borehole: 9 mm				
Foot base RE dimensions (to be attached to ELS3 lifting column) – pos. D					
Length:	750 mm				
Width :	90 mm				
Height:	20 mm				
Hole pattern:	Rectangular, 50 mm x 22 mm, borehole: 9 mm				
Installation kit – pos. E, F and G					
Countersunk bolt – pos. E :	M8 x 35 mm				
Raised head screw – pos F:	M6 x 10 mm				
Adjustable glide – pos. G :	M10 x 20 mm, diameter 63 mm				

Table 5 Technical specifications

IMPORTANT The dimensions of the tabletop must not protrude over the installed frame by more than 100 mm on the longitudinal side and 130 mm on the narrow side.

4.2 Design and function of the table frame

The table frame combined with the lifting columns, ELS3 system and a matching tabletop forms an electrically height adjustable workbench.

The table frame mainly consists of four components:

- Cross beam
- Fixing plate
- Foot base
- Installation kit

The individual components and the assembly of the table frame are described in the following.



Figure 1 Arrangement of the table frame components



Figure 2 FixFrame cross beam (length here = 1533 mm) – pos. A

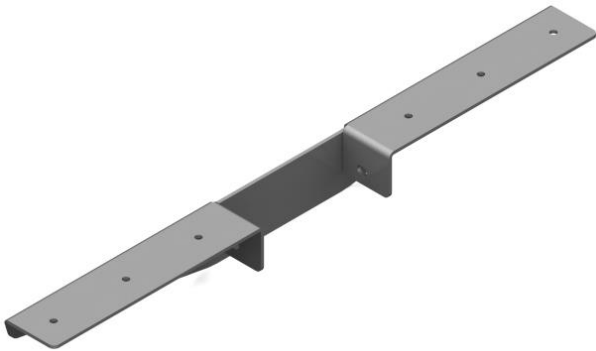

Figure 3 Fixing plate (length = 545 mm) – pos. B

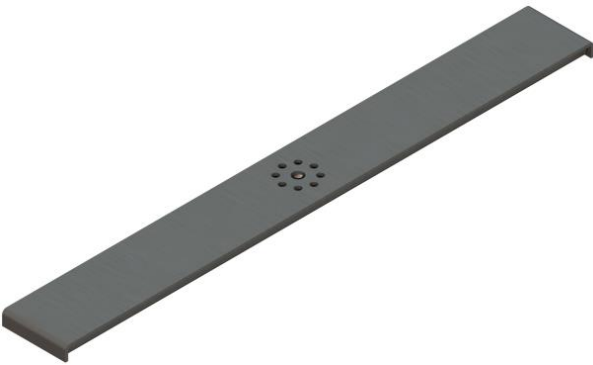

Figure 4 Foot base-Q (length = 750 mm) – pos. C

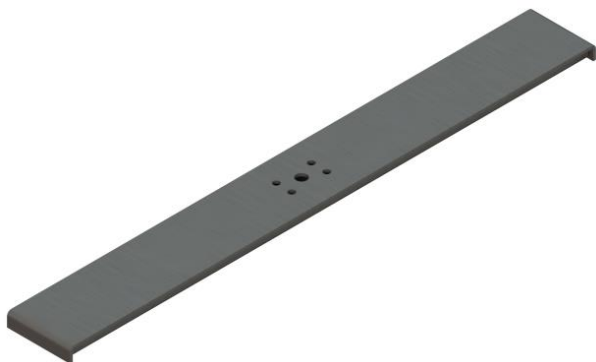

Figure 5 Foot base (length = 750 mm) – pos. D



Figure 6 M6 x 10 mm raised head screw – pos. E



Figure 7 M8 x 35 mm countersunk bolt – pos. F



Figure 8 M10 x 20 mm adjustable glide – pos. G

The cross beams (pos. A) and the fixing plates (pos. B) are fastened to the lifting columns using screws.

The foot base-Q (pos. C) foot base-RE (pos. D) are screwed to the bottom end of the lifting column.

The tabletop is screwed together with the cross beams (pos. A) and the fixing plates (pos. B).

4.2.1 Packaging units and weights

The complete table frame is combined into one packaging unit for individual acceptances. Therefore, the total weight of the packaging unit depends on the configuration of the table frame. The total weight of the packaging unit amounts up to 18 kg here, depending on the variant.

IMPORTANT When handling the packaging units, observe the respective weights of type FixFrame tabletops. In particular, adhere to applicable regulations, provisions and laws regarding the lifting and carrying of loads.

5 Installation



IMPORTANT

Observe the safety instructions!

For this purpose, please also refer to section "Safety instructions".

IMPORTANT The installation of the components must be carried out by specialized personnel of SUSPA GmbH, other specialized personnel and private persons.

IMPORTANT Check all components for any damage that may have occurred during transport or installation before operating the system. Do not try to dismantle the system or system components. Contact SUSPA GmbH in the event that components must be repaired or replaced.

5.1 Unpacking

Proceed with the necessary diligence and caution when unpacking the system components. Do not use any sharp-edged objects, cutters or knife blades in order to prevent damage to components that may get damaged easily.

- ➔ Check the delivery for completeness, damage or anything else that is conspicuous!
- ➔ Observe the applicable safety and accident prevention regulations during transport.
- ➔ Contact details can be found in section 2 "Identification".

5.1.1 Disposal of transport and warehouse packaging

The disposal of the transport and warehouse packaging should be performed in accordance with the local disposal regulations and environmental protection laws applicable in the operator's country.

5.1.2 Checklist of all components included in the delivery

Check the completeness of the delivery while unpacking the components. Use the appropriate delivery notes on the contents of the pallets and the manufacturer's packing list for this purpose.

Examples of scope of delivery would be:

1600 mm table frame for square lifting columns in RAL 9006:

- 2 x cross beams 1533 mm in RAL 9006
- 2 x fixing plates in RAL 9006
- 2 x foot bases-Q in RAL 9006
- 1 x installation kit

2000 mm table frame for rectangular lifting columns in RAL 9003:

- 2 x cross beams 1933 mm in RAL 9003
- 2 x fixing plates in RAL 9003
- 2 x foot bases-RE in RAL 9003
- 1 x installation kit

5.2 Operating conditions

Physical operating conditions	
Operating site	Office
Operating range:	Functional operation <ul style="list-style-type: none"> ▪ Minimum: + 15 °C ▪ Maximum: + 30 °C Relative humidity: <ul style="list-style-type: none"> ▪ 60 % maximum
Contamination:	No heavy contamination due to dust, acids, corrosive gases

Table 6 Operating conditions

- Do not operate the system outdoors. Do not expose the system to damp or wet conditions.
- Avoid environments with chemical agents or corrosive environments.
- Do not operate the system near flammable solvents, propellants and/or explosive substances (e.g. gas, vapor, dust, etc.).
- Do not expose the components of the table frame to any vibrations and/or shock loads.
- If stipulated operating conditions and maintenance instructions for the lifting column system are met, a service life of 10,000 cycles can be expected.

5.3 Installation of components

- Follow the instructions regarding the assembly of the table base frame with the tabletop specified in the schematic diagram of the table base frame (figure 9).

5.3.1 General installation

⚠ CAUTION Electrical components (lifting elements, electrical controllers, manual switches – not included in the scope of delivery) should be connected or disconnected only with the power plug pulled out!

- Install the table base frame centered under the tabletop (not included in the scope of delivery).
- For the assembly of the lifting columns (not included in the scope of delivery) with the table base frame, use provided screws only.
- Keep electrical cord away from sharp edges and moving parts.
- Avoid contact with moisture and heat.
- Attach the electrical wires and power cords to the workstation or structure using cable ties or clips.

IMPORTANT When laying cables, make sure that the cable is not crushed or stretched. Position the power cord to prevent tripping hazards. Use only accessories authorized and provided by SUSPA.

- First check whether the individual components are damaged. If this is the case, do not put the table base frame into operation, but have the damaged components replaced by your supplier.
- First check whether the lifting columns are damaged. If this is the case, do not put them into operation, but have the damaged components replaced by your supplier.
- Check whether the controller is damaged. If this is the case, do not put it into operation, but have the damaged components replaced by your supplier.
- Also check the power cable for damage. Make sure to replace damaged power cables in any case.

5.3.2 Installation of the table base frame

The following requirements must be met for the assembly of the table base frame (FixFrame table frame and ELS3 lifting columns) with a customized tabletop to form a fully assembled table:

- The table base frame is suitable for tabletops with a depth of 600 mm – 800 mm, see figure 9.
- The tabletop should not protrude more than 100mm on the longitudinal side over the table base frame, see figure 9.
- The tabletop should not protrude more than 130 mm on the narrow side over the table base frame, see figure 9.
- The table base frame may be loaded by a maximum of 90 kg. This load is the combined total of the tabletop weight and the additional load on the tabletop, such as a computer screen and keyboard, etc..
- The maximum load of 90 kg must be distributed evenly on the tabletop.

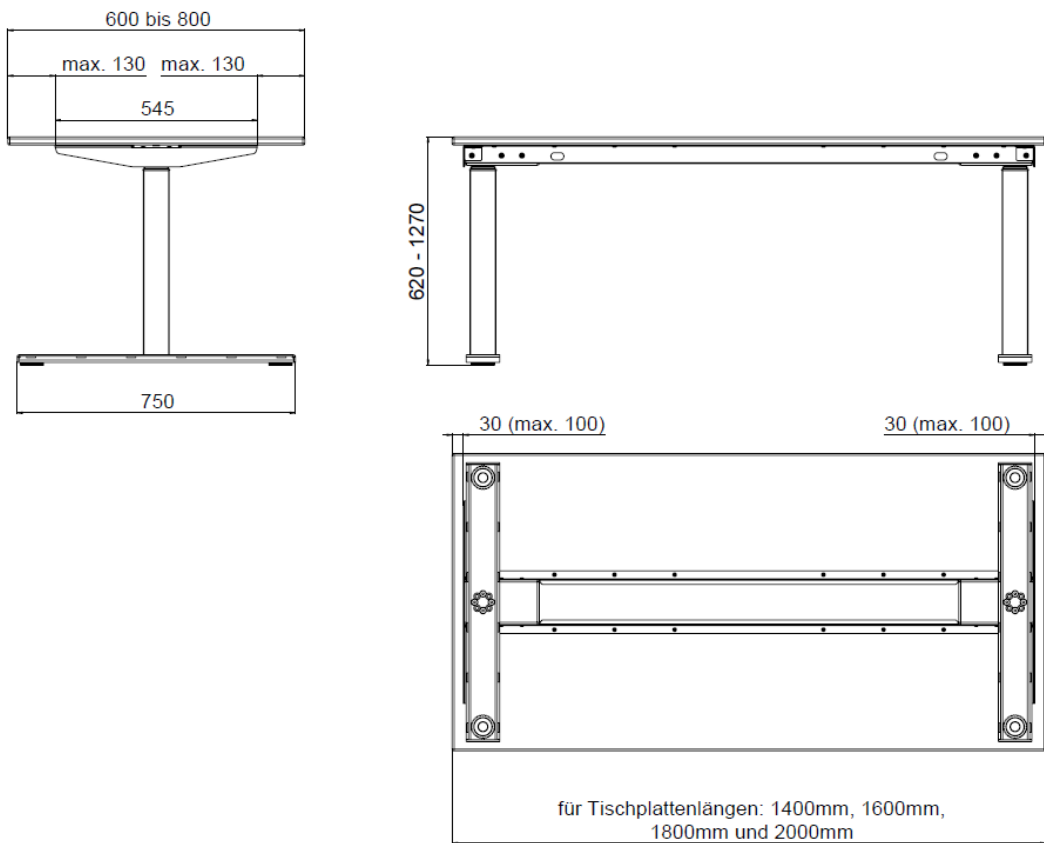

Figure 9 Alignment of the table base frame with the tabletop

5.3.2.1 Alignment of the lifting columns

- ➔ Remove the individual table frame components from the packaging.
- ➔ Remove the lifting columns (not included in the scope of delivery for the table frame) from the packaging.
- ➔ Place the tabletop (not included in the scope of delivery) with its top surface down onto a stable surface.
- ➔ Protect the top surface of the tabletop against scratching by placing cardboard underneath it.
- ➔ Place one lifting column each in the approximate center (referring to the depth of the tabletop) of the bottom surface of the tabletop.

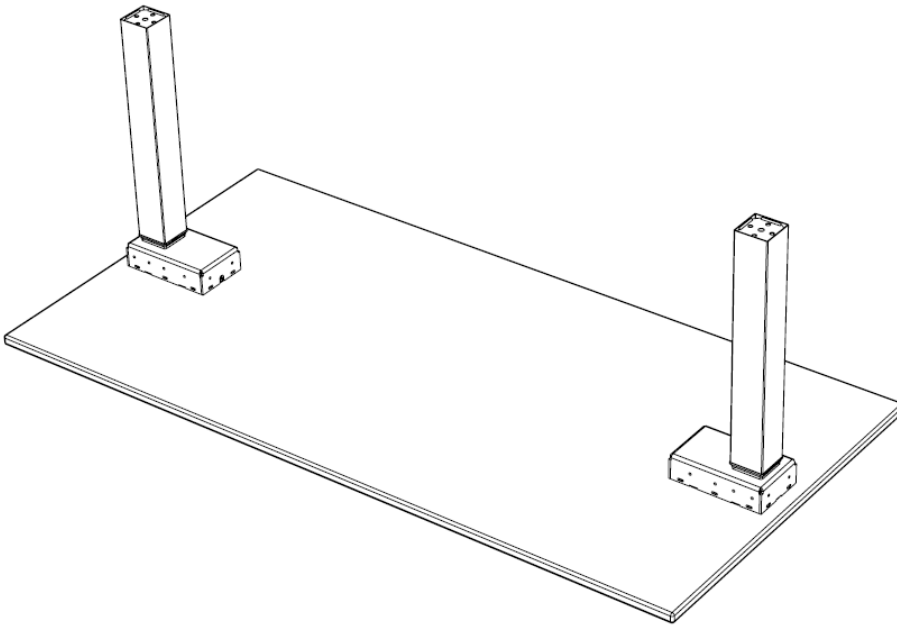

Figure 10 Positioning the lifting columns

5.3.2.2 Positioning the cross beams

- ➔ Place one cross beam each (pos. A) to the right and left of the lifting columns.
- ➔ The lifting columns and cross beams must be aligned with each other. The boreholes for the cross beam match the boreholes for the lifting columns.

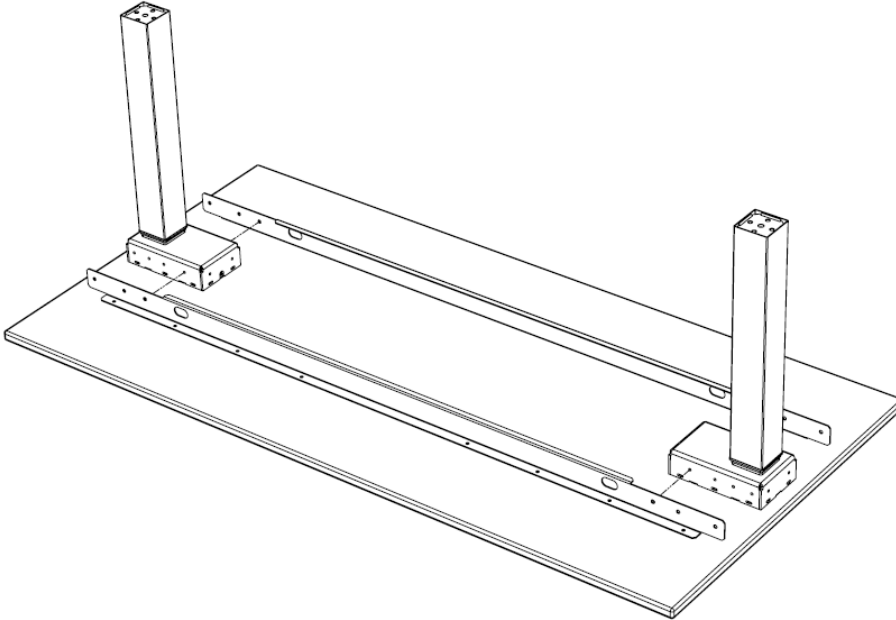

Figure 11 Positioning the cross beam (pos. A)

5.3.2.3 Positioning the fixing plates

- ➔ Place a fixing plate each (pos. B) in a way as to allow the clip of the fixing plate (pos. B) to clasp around the cross beams (pos. A) and the lifting column.
- ➔ The elongated holes in the fixing plate match the boreholes for the cross beam and lifting column.

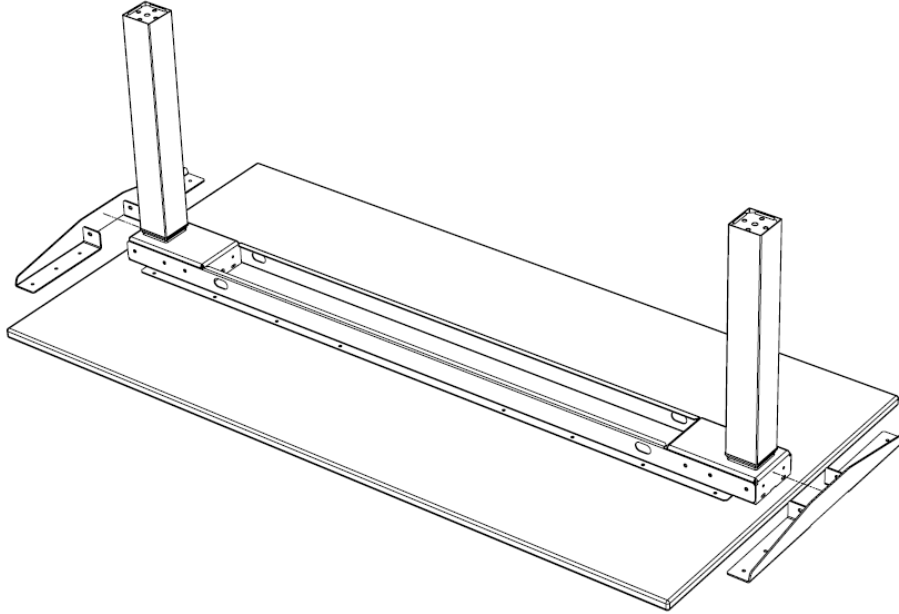

Figure 12 Positioning of the fixing plate (pos. B)

5.3.2.4 Screwing on the frame components

- ➔ Screw each lifting column to the cross beam (pos. A) and fixing plate (pos. B) - 6 x pos. E, M6x10 raised head screw.
- ➔ The maximum tightening torque for pos. E, M6x10 raised head screw is 7 Nm.

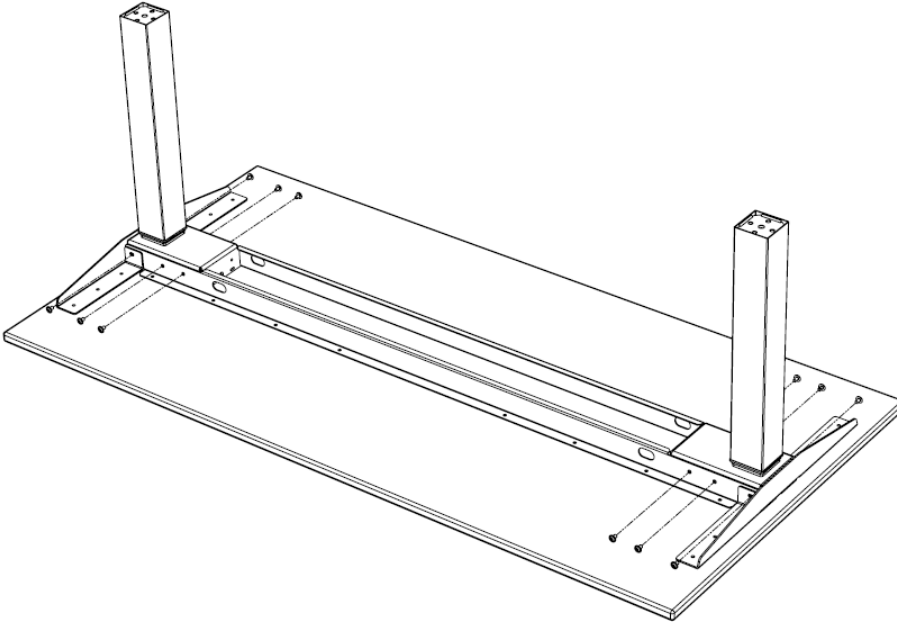

Figure 13 Cross beam screw connections

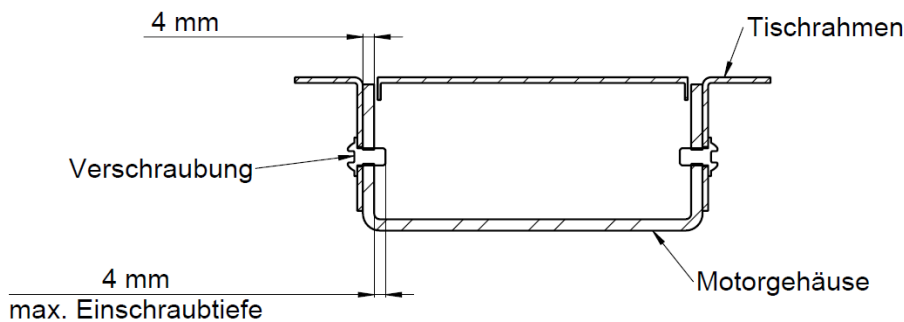

Figure 14 Maximum thread depth for the installation of the lifting columns

⚠ ATTENTION Make sure that the screws do not penetrate the housing by more than 5 mm.

When screwing the cross beam to the motor housing, make sure that the correct type of screw is used. Use only the supplied screws!

Observe the maximum torque of 10 Nm for the screws pos. E.

⚠ ATTENTION The lifting columns must be fastened with at least six screw connections between the frame and the lifting columns. For this purpose, at least three screws must be tightened with the respective torque on the longitudinal sides of the motor housing. If multiple bore holes are provided, additional screws may be added.

IMPORTANT Screws for fastening the lifting columns to the frame are not included in the scope of delivery.

5.3.2.5 Screw connection of the table base frame to the tabletop

- ➔ Align the table base frame in the center of the bottom of the tabletop.
- ➔ Screw the table base frame to the tabletop using 24 chipboard screws (or similar).

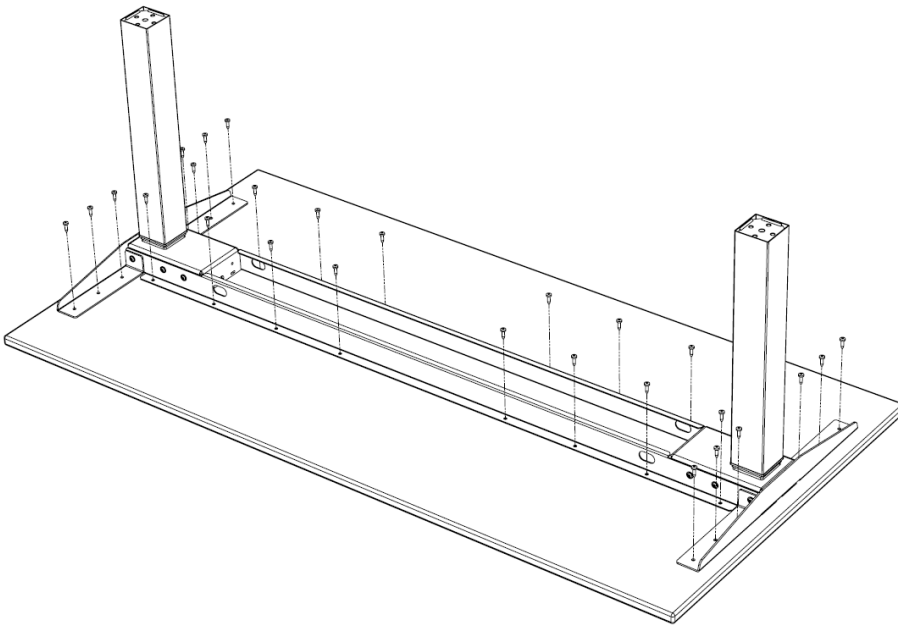

Figure 15 Screw connection of the table base frame

⚠ WARNING A risk of sustaining injuries due to protruding screws is posed.

⚠ ATTENTION Use screws with the proper length only.

Screws that are too long will penetrate the top surface of the tabletop and damage it!

IMPORTANT Screws to fasten the table base frame to the tabletop are not included in the scope of delivery.

5.3.2.6 Installation of the foot base and adjustable glides

- Screw the foot base (pos. C or pos. D) onto the lifting columns using M8 countersunk bolts (pos. F). The maximum tightening torque for pos. F, M8 screw is 10Nm.
- Retighten the screws crosswise to fasten the foot base to ensure they are well anchored.
- Ensure that the foot base are aligned parallel to the fixing plate (pos. B).
- Screw in the adjustable glides (pos. G) by hand into the designated threads on the foot base (pos. C or pos. D).

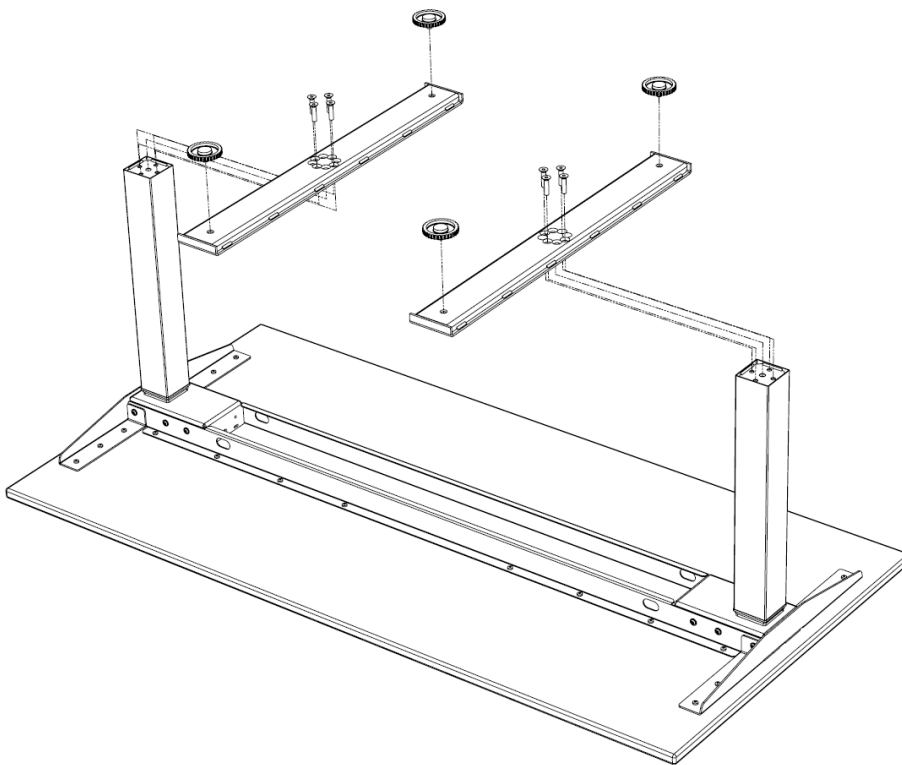

Figure 16 Screw connection of the foot base

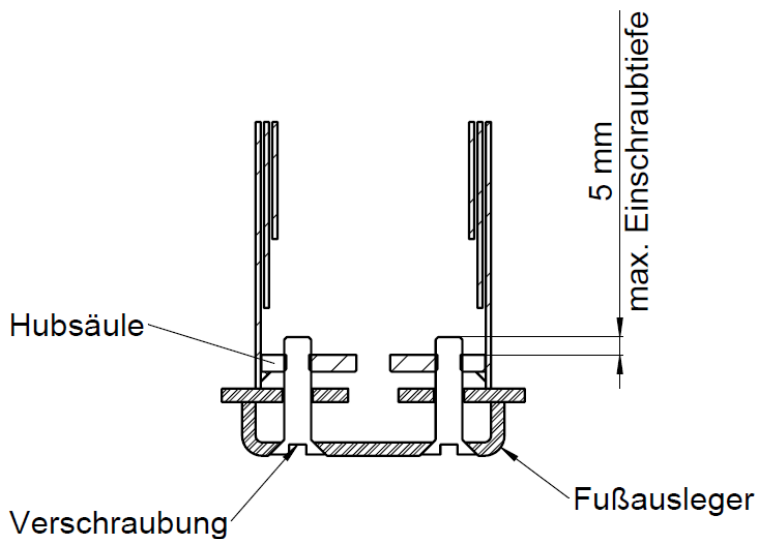

Figure 17 Maximum thread depth for the installation of the lifting columns

⚠ ATTENTION Use provided screws to attach the foot base (pos. F).

The functionality of the lift is only guaranteed when the supplied screws are used!

Observe the maximum torque of 10 Nm for the screws (pos. F)!

The foot base must each be fastened with four screw connections between the foot base and the lifting column. The screws are tightened crosswise with the specified torque.

5.3.2.7 Installation of the electrical controller (exemplary)

- ➔ Place the controller (not included in the scope of delivery) into the space between the two cross beams or at another suitable position on the bottom surface of the tabletop.
- ➔ Make sure that the connecting cable of the lifting columns can be plugged into the controller in any case.
- ➔ Ensure that the voltage supply cable (not included in the scope of delivery) can be plugged into the controller.
- ➔ Ensure that the cable of the hand-held controller (not included in the scope of delivery) can be plugged into the controller.
- ➔ Fasten the controller to the boreholes provided on the bottom of the tabletop between the two cross beams (2 fastening points).

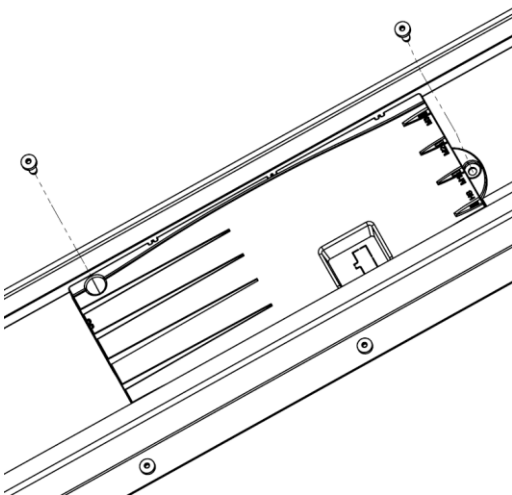

Figure 18 Installation of the controller

⚠ WARNING A risk of sustaining injuries due to protruding screws is posed.

⚠ ATTENTION Use screws with the proper length only.

Screws that are too long will penetrate the top surface of the tabletop and damage it!

IMPORTANT The controller must be fastened in a position that allows all lifting columns to be connected by the motor cable!

IMPORTANT The controller must always move with the lifting columns on their travel path!

IMPORTANT Screws to fasten the controller to the tabletop are not included in the scope of delivery.

5.3.2.8 Installation of the manual switch (exemplary)

- Fasten the manual switch (not included in the scope of delivery) in the required position on the tabletop.
- Ensure that the connecting cable of the manual switch can be plugged into the controller.

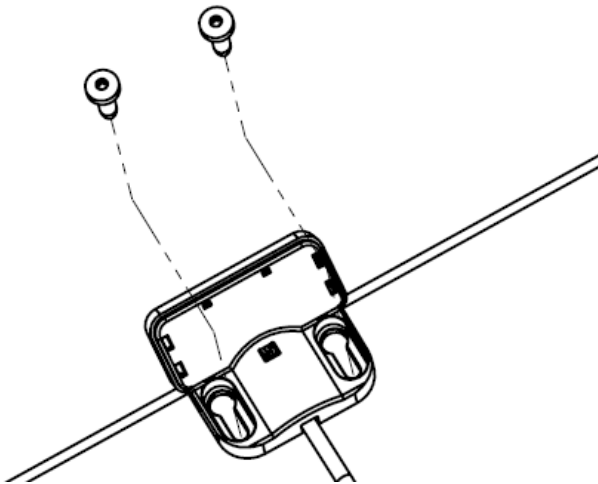

Figure 19 Installation of the manual switch

⚠ ATTENTION Use screws with the proper length only.

Screws that are too long will penetrate the top surface of the tabletop and damage it!

⚠ WARNING A risk of sustaining injuries due to protruding screws is posed.

IMPORTANT The manual switch must be fastened in a position that allows it to be connected to the controller!

IMPORTANT The manual switch must always move with the lifting columns on their travel path!

IMPORTANT Screws for fastening the manual switch to the tabletop are not included in the scope of delivery.

5.3.2.9 Connections and electrical lines (exemplary)

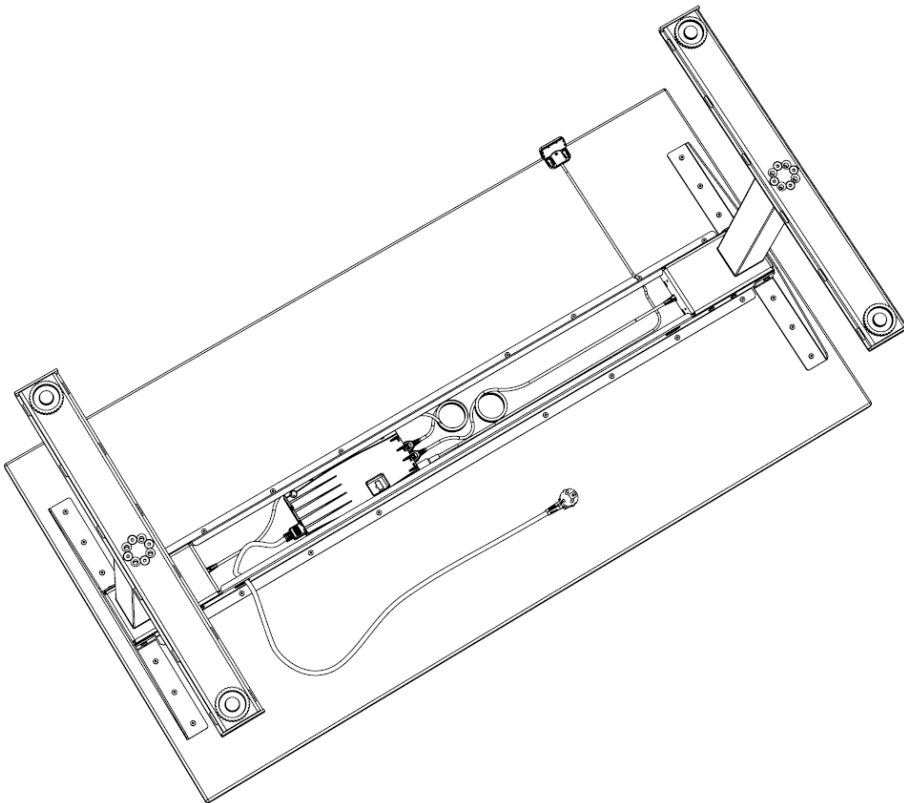

Figure 20 Connections for the electrical controller

- ➔ Connect the plug of the manual switch to the electrical controller using the appropriate input
- ➔ Plug the connectors of the lifting columns into the electrical controller.
- ➔ Plug the power connector into the matching input on the electrical controller.

IMPORTANT Ensure that only the controller provided with the ELS3 lifting columns is used to operate the table base frame.

5.3.2.10 Laying of electric wires and cables (exemplary)

- When laying the cables, make sure that
 - they cannot get jammed
 - they are not subjected to mechanical loads or stresses (tension, pressure or bending etc.)
 - they cannot be damaged in any other way
- Fasten the lines with adequate strain relief and adequate protection against kinks.
- Wind up long electrical lines and attach them with adequate cable holders (not included in the scope of delivery) on the bottom of the tabletop.
- Use caution so as not to damage the lines.
- Check the electrical lines and cables to ensure that they are fastened securely and have not been damaged.

5.4 Space requirements

For detailed information on space requirements refer to section 4.1 "Technical specifications".

5.5 Setting up and aligning the table

The table is aligned via the setting of the adjusting elements of the foot base.

- ➔ At least two people are needed to place the fully assembled table on its feet.
- ➔ If necessary, level the table using the adjustable glides.
- ➔ Reset the system. (see <https://suspa.com/suspa-downloads/> and <http://www.logicdata.net/de/download/>).

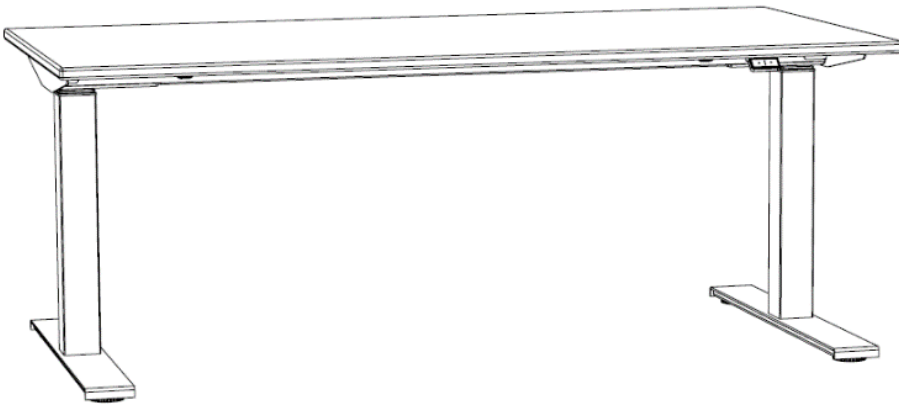

Figure 21 Fully assembled table

IMPORTANT Ensure that the adjustable glides are not unscrewed too far to protrude from the foot base.

6 Service and maintenance

6.1 General

- Observe and follow the general accident prevention guidelines.
- Carry out prescribed adjustment, maintenance, and upkeep work according to schedule.
- Replace defective components as quickly as possible.
- Only use tools that are in perfect condition.
- Keep suitable containers ready for small parts that may have to be disassembled.
- Use only original spare parts approved by the manufacturer.
- Tighten screw connections that have been loosened after doing maintenance and service work.
- Reattach disassembled protective devices before the first re-commissioning. Make sure that the protective equipment is functioning properly.
- Perform a functional test (test run) after maintenance or repair work.
- Check the proper function of all safety and protective devices.
- Remove any used tools, screws, aids or other objects from the operational area of the table base frame.

6.2 Maintenance instructions

6.2.1 Cleaning



WARNING

Risk of sustaining injuries by disregarding the manufacturer's instructions

The function of the components may be impaired as a result of ignoring the manufacturer's cleaning instructions.

Follow all applicable environmental regulations when cleaning.

- ➔ Remove all cleaning aids after performing cleaning work.
- ➔ Retract the table base frame before cleaning.
- ➔ Remove the load from all lifting elements before maintenance works.
- ➔ Unplug the motor control from the mains before cleaning.
- ➔ Clean the system components with a mild detergent and a damp cloth.
- ➔ Liquid entry of any kind must be strictly avoided.
- ➔ Do not use any corrosive detergents or high pressure washing systems to clean the components of the table base frame.
- ➔ Grease may be carried over during operation, leading to so-called run marks on visible pipe surfaces. These may be wiped off with mild cleaning agent and a cloth.
- ➔ Before restarting operation make sure the system is clean and dry.

6.3 Maintenance

The table base frame should be inspected on a regular basis. In case components are worn or damaged excessively, they must be replaced without delay.

6.3.1 Overloading the table frame

- ➔ Overloading the table frame must be avoided in any case.

IMPORTANT Drives that repeatedly turn off automatically are an indication that the system is overloaded.

6.3.2 Damages to electrical wires

Check the insulation of the electrical wires for visible signs of aging and wear. Replace defective or damaged wiring.

7 Decommissioning

7.1 Component storage

The storage area should be cool and dry in order to prevent corrosion of the individual parts of the table frame.

- Pack the table frame parts in such a way that they are protected from damages by external influences during storage.
- Use cardboard containers and other packing material, if necessary.
- Secure the table frame parts against accidental tilting and instability.

Transport and storage conditions	
Temperature:	-25°C to +60°C
Rel. humidity:	10% to 95% (non-condensing)

Table 7 Transport and storage conditions

7.2 Disposal of components

- Dispose of the packaging material in accordance with national regulations.
- Dispose of cardboard packaging, protective packaging made of plastics and preserving agents separately and professionally.

The users are obliged to return the old equipment to a recycling center for old electrical and electronic equipment.

The disposal of the controller is subject to the Elektro-G (Electrical Equipment Act), the EC Directive 2002/95/EC internationally (RoHS with effect from 7/1/2006) or the respective national legislation. The disposal of the components (also operating materials) in other countries should be performed in accordance with the local disposal regulations and environmental protection laws in the country where the machine is used.

If the equipment has reached the end of its life cycle, ensure a safe and professional disposal when dismantling, in particular for those parts or substances which are hazardous for the environment. This includes lubricants, plastics and batteries etc.

- Have the machine disposed properly by an authorized specialist company on account of the potential risk of environmental pollution.

8 Appendix

8.1 Index of Tables

Table 1 Signal words and signal colors.....	5
Table 2 Symbols.....	6
Table 3 Warning notice	6
Table 4 Target group	10
Table 5 Technical specifications.....	13
Table 6 Operating conditions.....	18
Table 7 Transport and storage conditions	35

8.2 Index of Figures

Figure 1 Arrangement of the table frame components	14
Figure 2 Cross beam (length here = 1533 mm) – pos. A.....	14
Figure 3 Fixing plate (length = 545 mm) – pos. B	15
Figure 4 Foot base-Q (length = 750 mm) – pos. C.....	15
Figure 5 Foot base-RE (length = 750 mm) – pos. D	15
Figure 6 M6 x 10 mm raised head screw – pos. E.....	15
Figure 7 M8 x 35 mm countersunk bolt – pos. F	16
Figure 8 M10 x 20 mm adjustable glide – pos. G	16
Figure 9 Alignment of the table base frame with the tabletop.....	20
Figure 10 Positioning the lifting columns.....	21
Figure 11 Positioning the cross beam (pos. A)	22
Figure 12 Positioning of the fixing plates (pos. B).....	23
Figure 13 Cross beam screw connections.....	24
Figure 14 Maximum thread depth for the installation of the lifting columns.....	24
Figure 15 Screw connection of the table base frame	25
Figure 16 Screw connection of the foot base.....	26
Figure 17 Maximum thread depth for the installation of the lifting columns.....	27
Figure 18 Installation of the controller	28
Figure 19 Installation of the manual switch.....	29
Figure 20 Connections for the electrical controller	30
Figure 21 Fully assembled table	32